 Hot water heat

1 model

CE

Fan heater SW 02

Fan heaters for water connection. Extremely quiet

Fan heater SW02 is a newly developed, extremely quiet and well-designed fan heater for water connection. These qualities make the heater suitable for places where fan heaters are traditionally used, such as industrial premises, workshops and storage rooms, as well as places where low noise levels are required like shops, supermarkets and meeting halls.

- Extremely quiet.
- Corrosion proof casing of hot zinc-plated and powder lacquered steel panels. Colour code: RAL 9016.
- Three fan speed stages.

Technical specifications | Fan heater SW 02

Type	Heat output* ¹ [kW]	Airflow* ² [m ³ /h]	Sound level* ³ [dB(A)]	Voltage [V]	Max input	Weight [kg]
SW02	8-10	0,20/0,31	34-45	230V~	0,31	15

*¹) Applicable at water temperature 80/60°C, surrounding temperature +15°C, fan position min-max.

*²) Applicable at fan position min-max

*³) Applicable at fan position min-max. Conditions: Distance to fan 5 m. Direction factor: 2. Equivalent absorption area: 200 m².

Protection class SW02: (IP44), splash-proof design.
CE compliant.

Dimensions

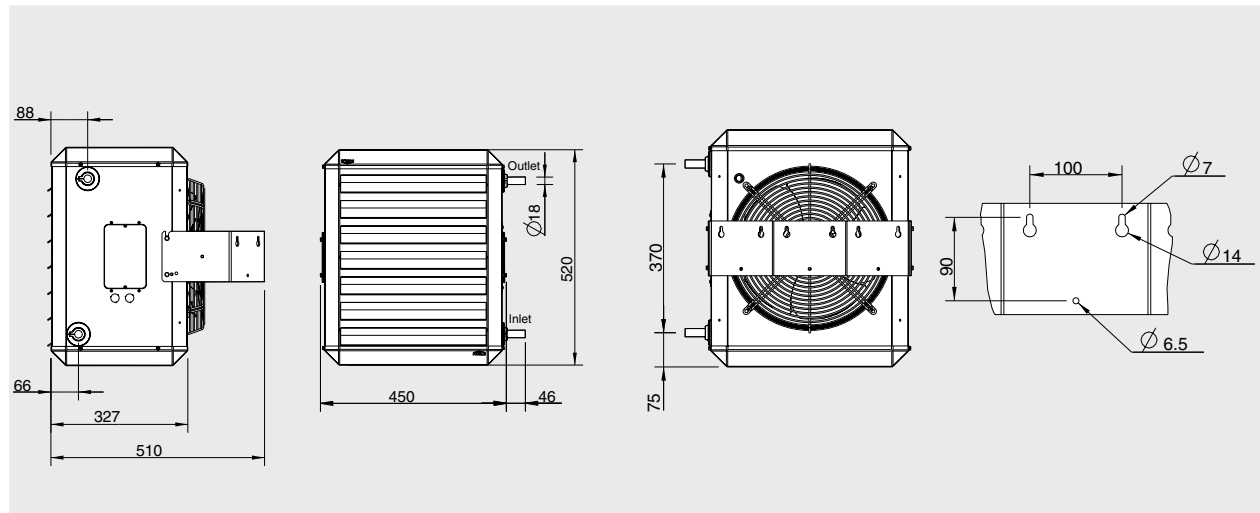

Mounting

Fan heater SW02 is delivered with casing, fan, heating coil, bracket and air director as standard.

SW02 can be mounted on the wall for horizontal air distribution or on ceiling for vertical air distribution.

SW02 can be mounted with the pipes either to the left or to the right.

Accessories

Type	Description
CB30N	Control panel
SWR20*	Valve set, 3/4"
TVV20	2-way valve, 3/4"
SD20	Actuator on/off
RTI2	El. 2-stage thermostat
RTE102 (15A)	Electronic thermostat
RTEV102V (15A)	Electronic thermostat
KRT1900 (16A/10A)	Capillary tube thermostat, IP55
KUR	Time switch
SWFT02	Filter

* = AV20 + JV20 + TVV20 + SD20

