



⚡ Electrical heat 2-30 kW

12 models

CE

Fan heater Tiger

Portable fan heater

Tiger is a series of compact and robust fan heaters for portable use.

Tiger can be divided into three different sizes according to their output.

Tiger 2–9 kW is suitable for use in workshops, garages and shops. It can easily be mounted on the wall (brackets LT22406 are ordered separately). The built-in thermostat regulates fan speed and heat, or heat only. The choice is made with the mode selector.

Tiger 15 kW is designed for heating and drying when there is large output requirements. Suitable application areas are for example building sites, industries, mines and workshops. It can easily be mounted on the wall (brackets LT22406 are ordered separately).

Tiger 20 and 30 kW are designed for heating and drying when there is large output requirements. Suitable application areas are for example building sites, industries, mines and workshops. Tiger 20 and 30 kW have a change-over switch for full/half airflow.

- Very reliable and extremely robust.
- Corrosion proof casing of hot zinc-plated and powder lacquered steel panels. Colour: RAL 3020.
- Delivered with 1.8 meter cable.
 - P21 and P31 are delivered with plug for connection to an earthed wall socket (P31 requires 16 A fuse).
 - P33, P53 and P93 have a CEE plug on the cable. P153, P203, P303 and P305 are delivered with cable without plug.
- On the back of P33, P53 and P93 there is a 230V~ socket for lamps, drills and similar.
- All units are equipped with manual reset for overheat protection.
- The robust tubular stand is used as a handle and Tiger 2–15 kW can be wall mounted.

Fan Heater Tiger



On the back of P33, P53 and P93 there is 230V~ socket for lamps, drills etc. Convenient on building sites!



Tiger is available in sizes from 2 to 30 kW. The small units are delivered with cable and plug and give fast heat contribution in for example garages and smaller premises.



Tiger makes it easy to move the heat to where it is needed; where people are!

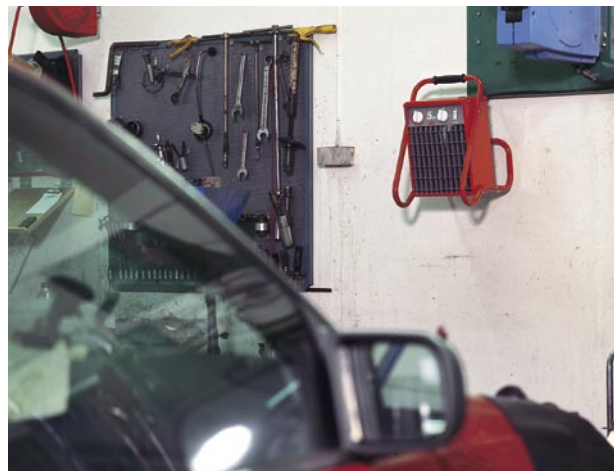

Tiger is primarily intended for portable use, but the 2-15 kW models can easily be wall mounted to be out of the way.



The robust and portable design combined with an output of 30 kW makes Tiger unbeatable in tough environments with demand for temporary heating.

Fan Heater Tiger

Technical specifications | Fan heater Tiger, 2-9 kW

Type	Output stages [kW]	Air flow [m ³ /h]	Sound level* ¹ [dB(A)]	Δt * ² [°C]	Voltage [V]	Amperage [A]	HxWxD [mm]	Weight [kg]
P21	0/1.5/2	280	41	18	230V~	8.8	450x290x390	5.7
P31	0/2/3	280	41	27	230V~	13.2	450x290x390	6.0
P33	0/1.5/3	280	41	27	400V3N~* ³	4.4	450x290x390	6.3
P53	0/2.5/5	480	40	31	400V3N~* ³	7.3	450x290x390	6.7
P93	0/4.5/9	720	44	37	400V3N~* ³	13.1	530x350x480	10.2

*1) Conditions: Distance to the unit 3 metres. Directional factor: 2. Equivalent absorption area: 200 m².

*2) Δt = temperature rise of passing air at maximum heat output.

*3) Also available without neutral.

Protection class Tiger, 2-9 kW: (IP44), splash-proof design.

Approved by SEMKO and CE compliant.

Technical specifications | Fan heater Tiger, 15 kW

Type	Output stages [kW]	Air flow [m ³ /h]	Sound level* ¹ [dB(A)]	Δt * ² [°C]	Voltage [V]	Amperage [A]	HxWxD [mm]	Weight [kg]
P153	0/7.5/15	1120	47	43	400V3N~	21.9	510x410x530	15.9

*1) Conditions: Distance to the unit 3 metres. Directional factor: 2. Equivalent absorption area: 200 m².

*2) Δt = temperature rise of passing air at maximum heat output.

Protection class Tiger, 15 kW: (IP44), splash-proof design.

Approved by SEMKO and CE compliant.

Technical specifications | Fan heater Tiger, 20 and 30 kW

Type	Output stages [kW]	Air flow [m ³ /h]	Sound level* ¹ [dB(A)]	Δt * ² [°C]	Voltage [V]	Amperage [A]	HxWxD [mm]	Weight [kg]
P203	0/10/20	1900/2600	60	31/23	400V3N~	29.5	590x630x600	25.5
P303	0/10/20/30	1900/2600	52	47/34	400V3N~	43.9	590x630x600	29.5
P305	0/7.5/15/23	1900/2600	52	36/26	440V3N~	30.8	590x630x600	30.0
(convertible)	0/10/20/30			47/34	500V3N~	35.1		

*1) Conditions: Distance to the unit 3 metres. Directional factor: 2. Equivalent absorption area: 200 m².

*2) Δt = temperature rise of passing air at maximum heat output and lowest/highest air flow.

Protection class Tiger, 20 and 30 kW: (IP44), splash-proof design.

Approved by SEMKO and CE compliant.

Dimensions

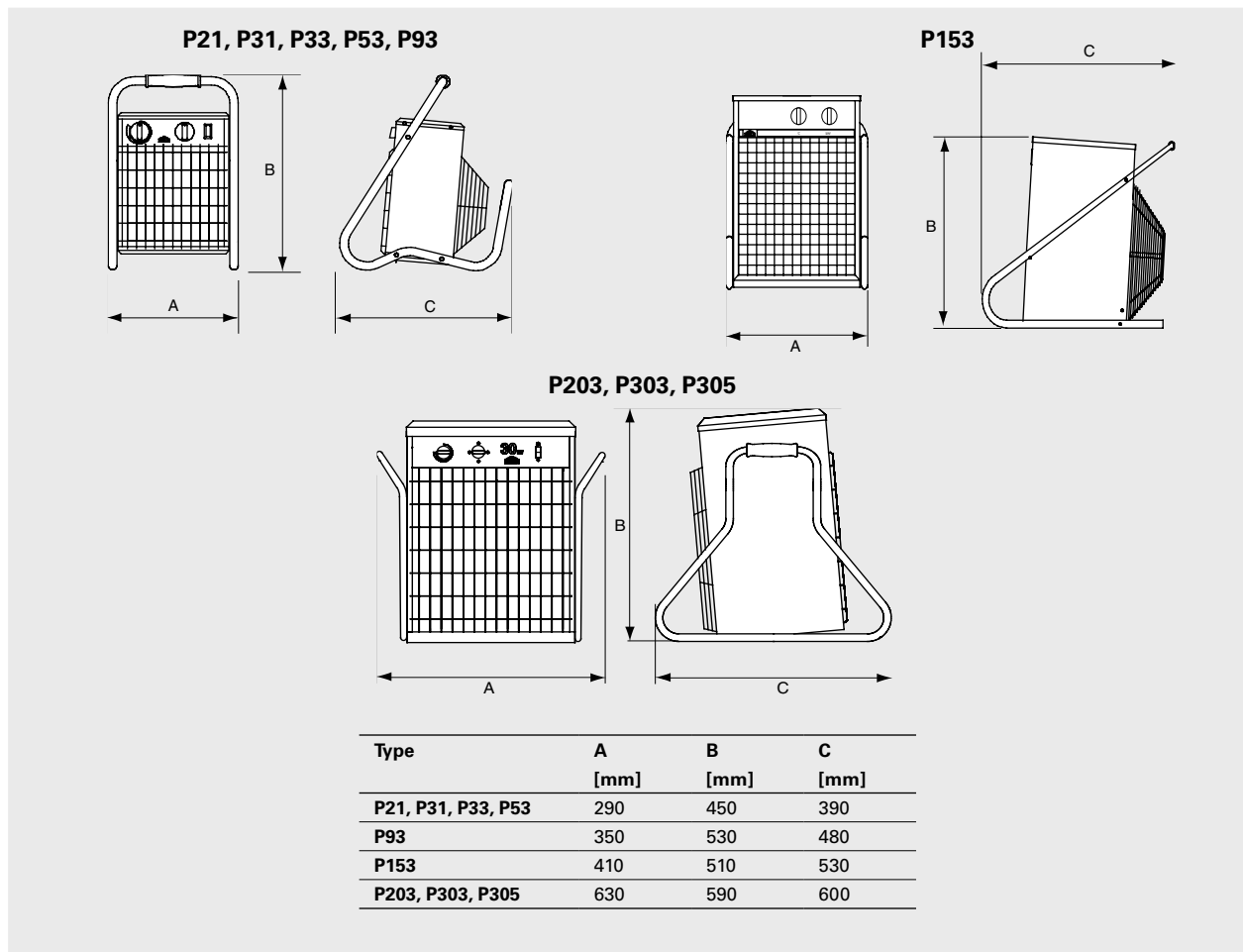

Fan Heater Tiger

Positioning, mounting and installation

Mounting

The units are primarily portable, but units up to 15 kW can also be mounted on the wall. Either mounting fixed on the wall through the holes (\varnothing 6 mm) on the back side of the stand or if the unit should be easier to move with mounting bracket LT22406, see Fig. 2. For minimum mounting distance, see Fig. 1.

Connection

All Tiger fan heaters are delivered with 1.8 m cable. P21 and P31 are delivered with plug for connection to an earthed wall socket (P31 requires 16 A fuse). P33, P53 and P93 have a CEE plug on the cable. 153, P203, P303 and P305 are delivered with cable without plug.

On the back of P33, P53 and P93 there is a 230V~ socket for lamps, drills and similar.

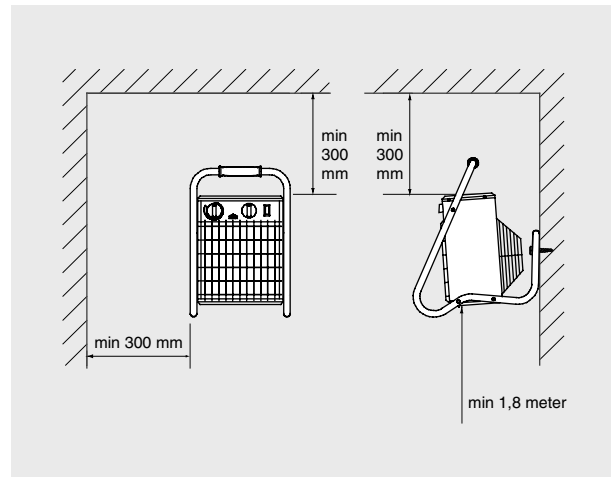

Fig. 1: Minimum distance for fixed installation.

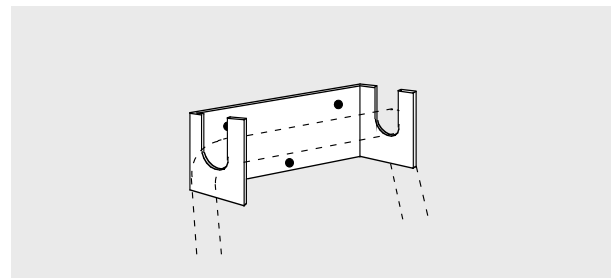

Fig. 2: Mounting with mounting bracket LT22406.

Regulation

Tiger, 2–9 kW

The built-in thermostat regulates fan speed and heat, or heat only. The choice is made with the mode selector. In the later alternative the fan blows constantly and the thermostat only controls the heat output. Thermostat with setting range 5–35°C. Output is set via the output selector, for stages see table.

Tiger, 15 kW

Built-in thermostat with setting range 5–35°C. Output is set via the output selector, for stages see table.

Tiger, 20 and 30 kW

Built-in thermostat with setting range 5–35°C. Output is set via the output selector, for stages see table. The mode selector has two different fan speed positions.